

At the end of the day/shift, or if the printheads are not being used for several hours, use the machine capping station to protect the printheads from dirt, debris and light.

3

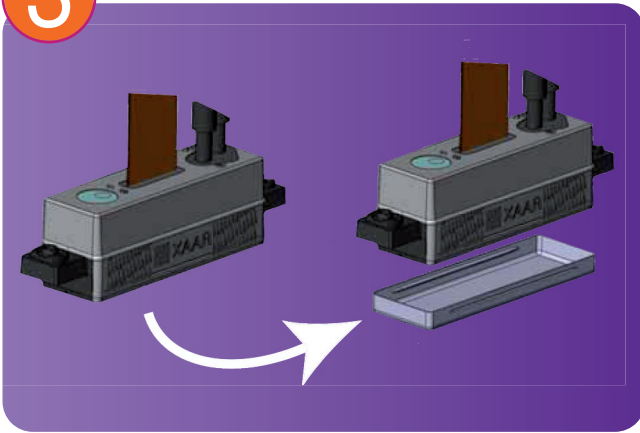

After longer periods of shutdown, follow the manufacturer's procedures for restart and carry out the cleaning procedures in Step 2.



Do NOT touch the sensitive parts of the printhead. Always protect the printhead from static damage and wear gloves at ALL times.

*Also for the Xaar 1001 and 1002.

Xaar plc
316 Science Park
Cambridge
CB4 0XR
United Kingdom
+44 (0)1223 423663
info@xaar.com
www.xaar.com



Issue 6 January 2016 English

DAILY PRINTHEAD MAINTENANCE

Xaar 1003

YOUR PRINTHEADS
ARE VALUABLE
TREAT THEM WITH
CARE



DAILY PRINTHEAD MAINTENANCE

The printhead is a precision high-quality product. Protect and care for it to ensure optimal performance.

At the start of the day/shift carry out a visual inspection of the printhead for contamination or debris.

Detailed below is the procedure for cleaning contamination from the printhead. Always use the correct method for wiping the nozzle plate.

⚠ Always refer to the machine manufacturer's maintenance procedures.

